

# SLIDING TOOL TRAY FOR WORK PLATFORMS - WP-TT36

APPROX WEIGHT: 13.20 lbs.  
 DOES NOT INCLUDE WEIGHT OF POWER OR PACKAGING!!!

\*\*\* ANY ADDITIONS, DELETIONS, OR OMISSIONS MUST BE CORRECTED ON THIS DRAWING AS THIS DRAWING WILL BE CONSIDERED ALL INCLUSIVE \*\*\*

ALL GRAPHICS PROVIDED ARE FOR REFERENCE ONLY. IF CERTAIN DIMENSIONS ARE CRITICAL PLEASE VERIFY THOSE DIMENSIONS WITH YOUR SALESPERSON

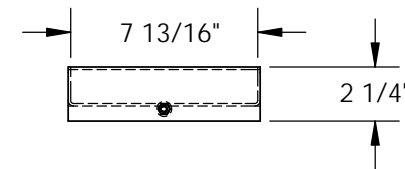
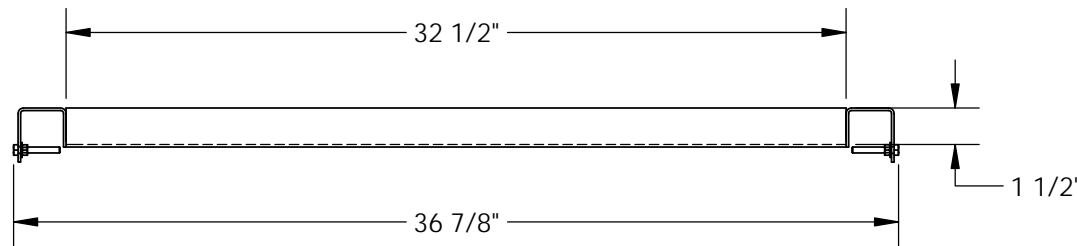
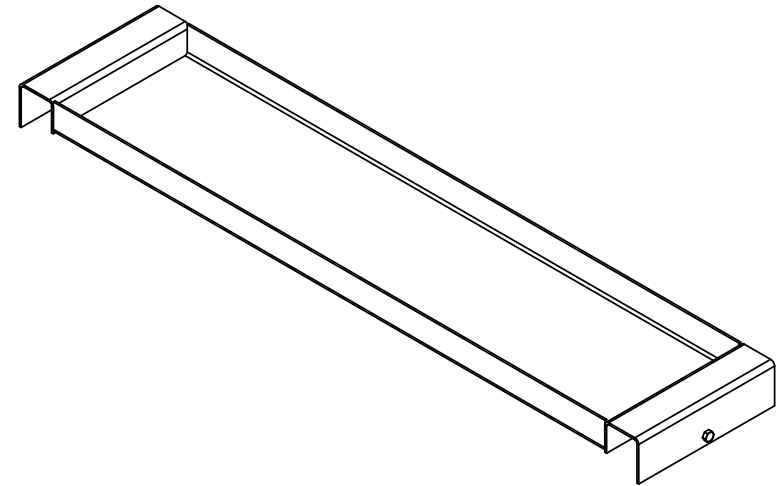
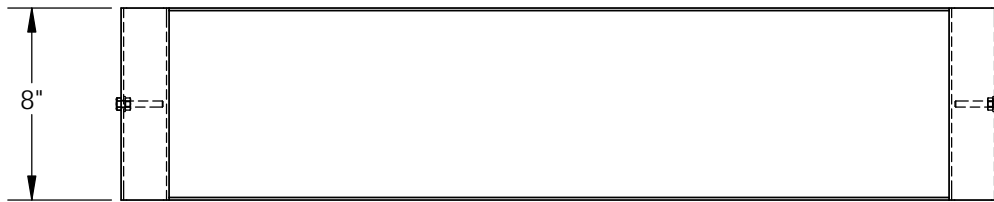

DIMENSION TOLERANCE ± 1/4"

## STANDARD FEATURES

- MODEL NUMBER IS WP-TT36
- OVERALL WIDTH IS 36 7/8"
- USABLE WIDTH IS 32 1/2"
- OVERALL DEPTH IS 8"
- USABLE DEPTH IS 7 13/16"
- OVERALL HEIGHT IS 2 1/4"
- USABLE HEIGHT IS 1 1/2"
- STEEL CONSTRUCTION
- BLUE POWDERCOAT FINISH

## SPECIAL FEATURES

NONE

**\*\*THIS TOOL TRAY IS TO BE USED IN CONJUNCTION WITH 36"W SINGLE DOOR WORK PLATFORMS\*\***

|   |  |  |
|---|--|--|
| <b>A<br/>P<br/>P<br/>R<br/>O<br/>V<br/>A<br/>L</b>                  | I, THE UNDERSIGNED, AGREE THAT THE PRODUCT AS REPRESENTED SATISFIES DESIGN AND DIMENSION REQUIREMENTS. I ALSO ACKNOWLEDGE MY DUTY TO CONFIRM PRODUCT AND INSTALLATION COMPLIANCE WITH ALL APPLICABLE FEDERAL, STATE AND LOCAL REGULATIONS AND STANDARDS. |  |
|   | <b>ANY MODIFIED UNITS ARE NON-RETURNABLE</b>   |  |
|   | [ ] As drawn      [ ] As marked  |  |
| Signed: _____ Date: _____   |  |  |
| Printed Name: _____   |  |  |
| <i>LEAD TIME WILL START UPON RECEIPT OF SIGNED APPROVAL DRAWING</i> |  |  |

|   |  |
|---|--|
| FOR INTERNAL USE ONLY<br>PROJECT SIGN OFF |  |
| SALES                                     |  |
| ENG.                                      |  |
| FAB.                                      |  |
| POWER                                     |  |

|                      |          |            |
|----------------------|----------|------------|
| DISTRIBUTOR'S NAME:  |          | P.O.#      |
| VESTIL MANUFACTURING |          | X          |
| DRAWN BY:            | DATE:    | W.O.#      |
| TJM                  | 04/27/16 | X          |
| REFERENCE:           | SCALE:   | FILE NAME: |
| X                    | 1:8      | 14-007-306 |
| QUOTED LEAD TIME:    | QUOTE #  |            |
| X                    | X        |            |